

3D & AUGMENTED REALITY SYSTEM

SATORI

Immersive Product Catalog System

About

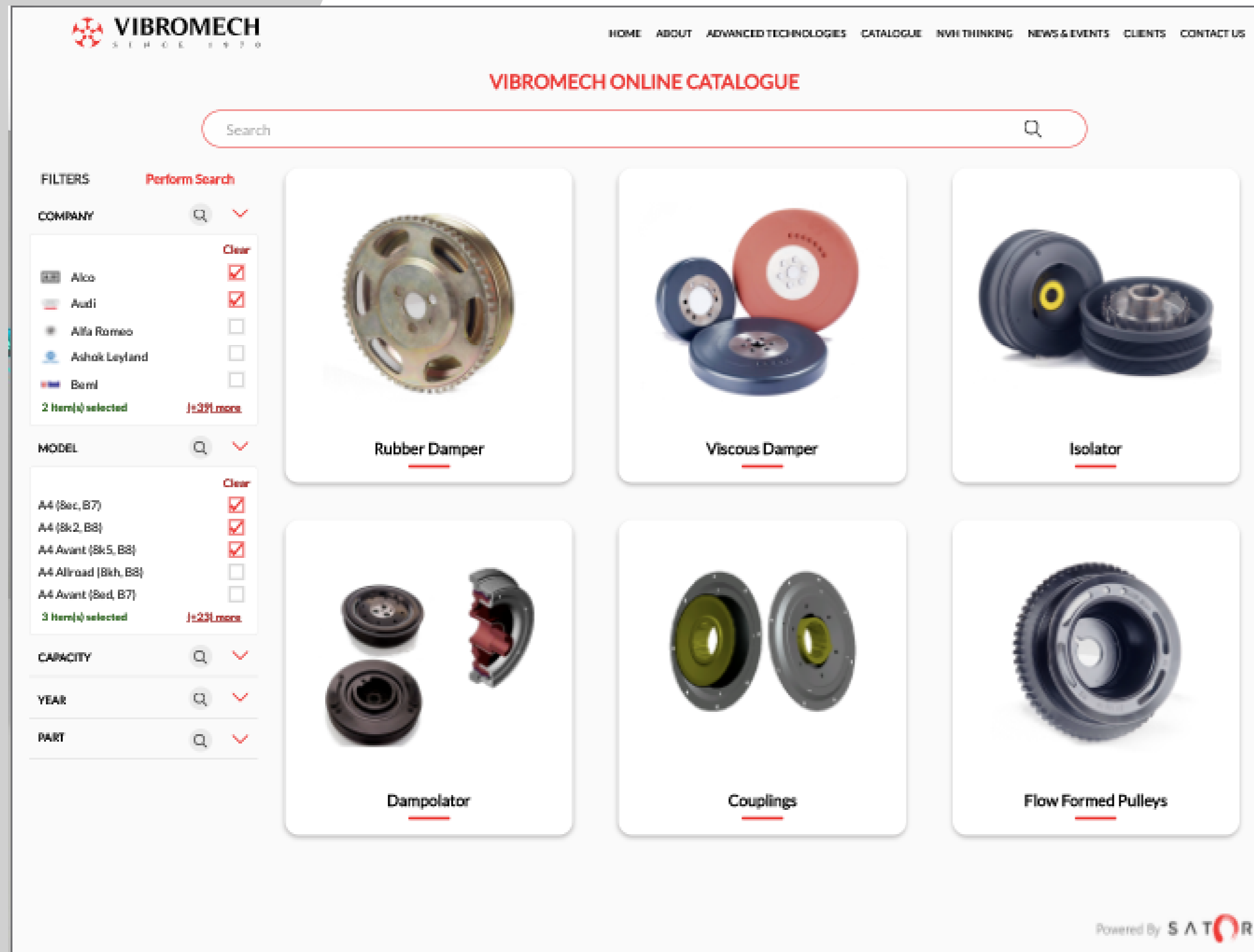

The satori 3D catalog with Augmented Reality, allows your prospective buyer to :

- Interact with and understand your product.
- Enhance her buying experience.
- Enjoy greater confidence in their choice, reducing errors and returns.

The Satori 3D catalog is available for web, mobile and PC platforms

Needs & Challenges?



Product Specifications Vs Customer Expectations Vs Presentation Limitations

- Sales process is a tug-of-war between customer expectations and the limitations of what a catalog can show.
- Lack of product engagement.
- Cannot demonstrate full scope of the product .
- 2D pictures and text are inadequate.

Printed & Web Catalog

- Not engaging
- Not interactive.
- Browsing the website is very tedious
- No touch and feel

Created by Eucalyp

Attention and Immersiveness

- Lack of attention
- Cannot visualize the product

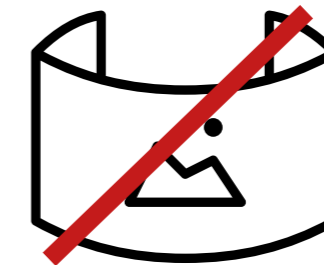

Website navigation and Filtering system

- Takes a lot of time to arrive at required product
- Does not contain all the required information
- 2D/3D Cad data is not available

Created by Vicons Design
from the Noun Project



Created by Eucalyp

3D & AUGMENTED REALITY SYSTEM

SATORI

Product Impact on Customer

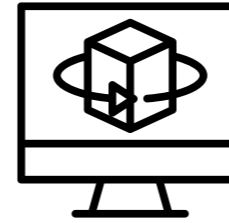
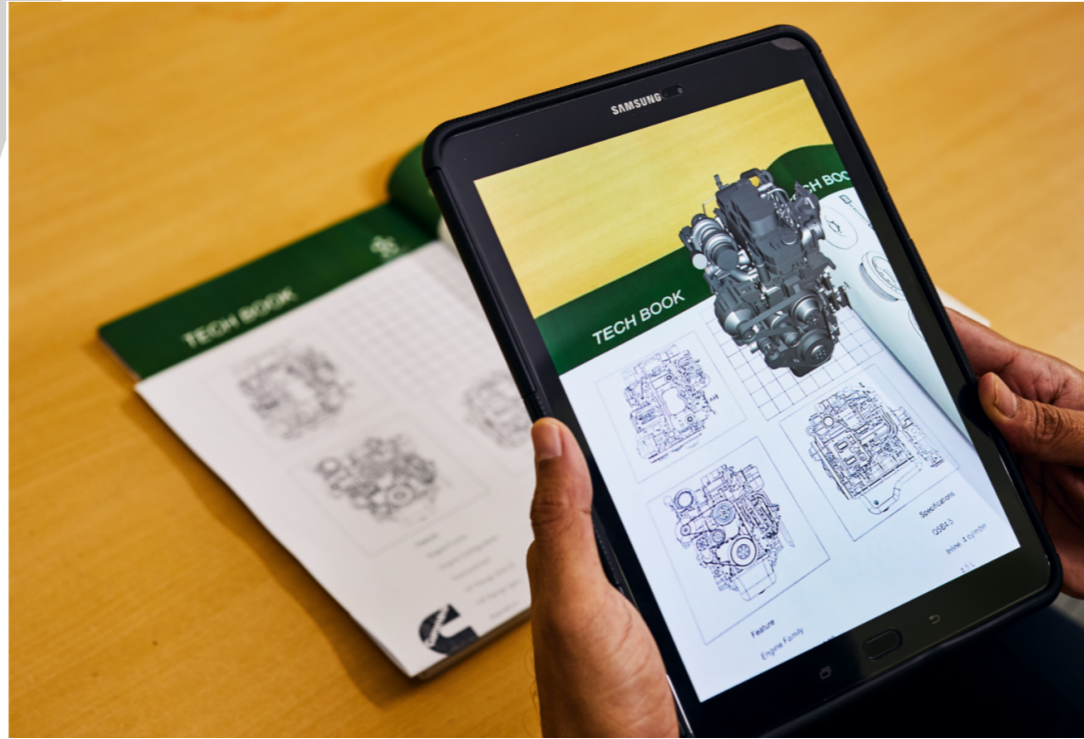

Dramatic impact

- Engrossing visuals
- 3D models
- Point of View



Customers point view

- 3D animations of the products as per storyboards
- An extensive filtering system for hassle free product selection
- Enhance situational awareness and empirical understanding
- Retention of knowledge and expertise
- Gamified Interaction

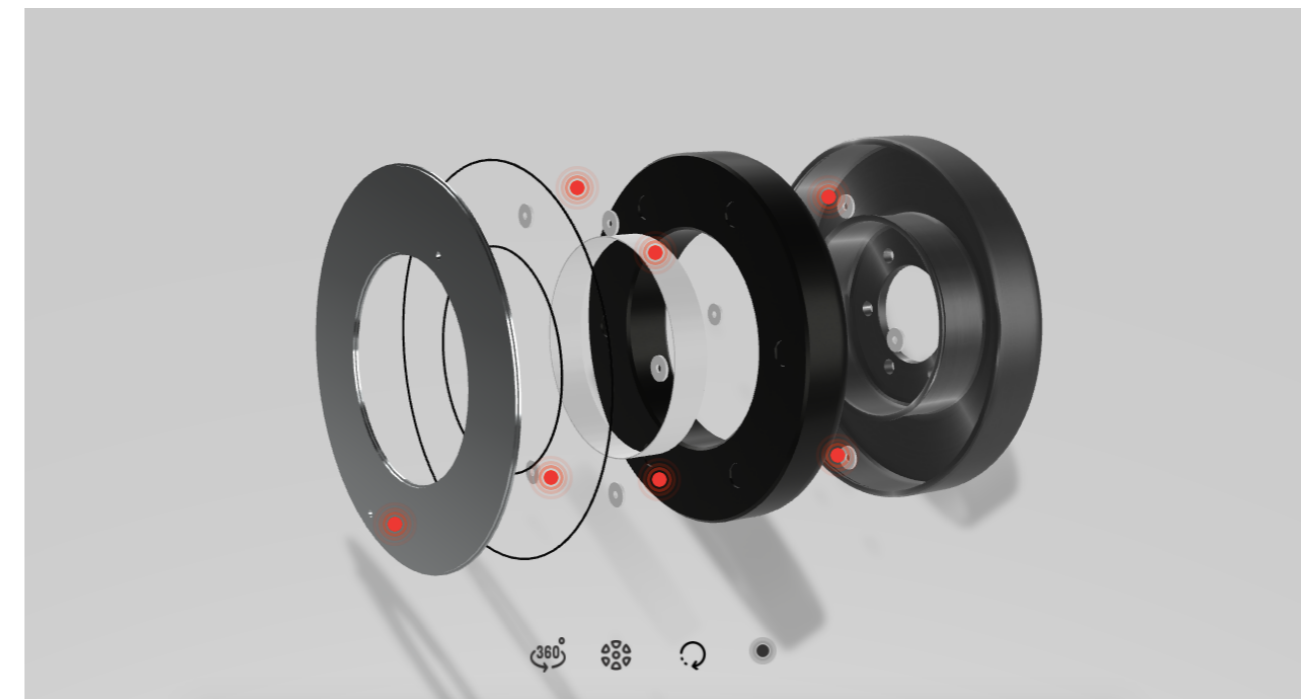

3D & AUGMENTED REALITY SYSTEM

SATORI

Benefits to the company



Status and Profile

- Raise the profile
- High tech
- Technology leadership
- Modern Pedagogy

Created by Iconpeck
From the Noun Project

Other Advantages:

- Digital twins of all the models
- Immersive models attract more customers
- Increased pace of learning and fault detection
- Deeper learning through interactivity
- Fewer distractions

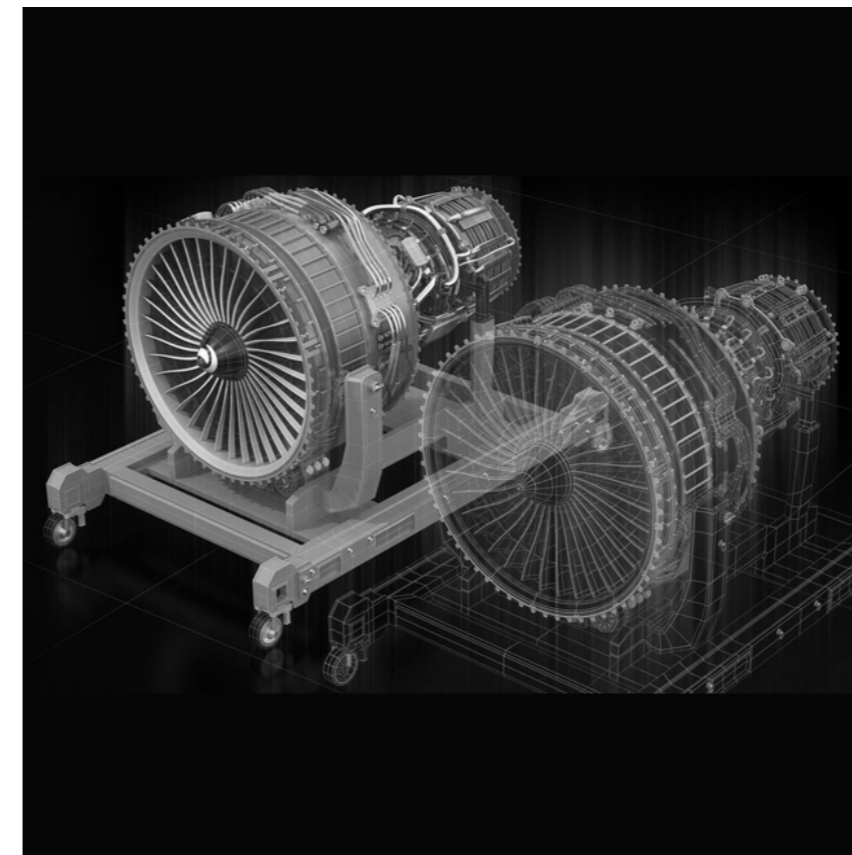

3D & AUGMENTED REALITY SYSTEM

SATORI

Contact:
marketing@vibromech.com